

# PRODUCT SPECIFICATION

## EG8200mini



Chengdu Zongheng Intelligence  
Control Technology Co., Ltd.

PRODUCT  
INTRODUCTION

产品介绍 ▶▶▶



EG8200mini series products are edge computing gateways launched by IOTRouter Chengdu. With its **rich hardware interfaces, drag-and-drop programming method, Zero Code design concept, convenient remote management** and other characteristics, It can **quickly, flexibly, accurately** and **efficiently** respond to various IoT industry needs.

EG8200mini abstracts complex hardware interfaces, different industrial network protocols, etc. into Nodesone by one. Users can **use these Nodes flexibly to replace the traditional complex and inefficient coding process** by dragging and connecting. Really let customers focus on business logic and quickly create their own gateway equipment. The mission of EG8200mini is to continuously develop new Nodes to serve industry customers to **adapt to the fragmentation of IoT industry needs**.

## PRODUCT SPECIFICATION

## 产品规格



Hardware	CPU	2*Cortex-A7@1.2GHz
	Memory	512M
	EMMC	4G (MLC)
	SD card	Up to 128G (influxdb pre-installed)
	RTC	Real Time Clock
	Wireless	LTE Cat4
	WAN	1*1000/M Support DHCP Client
	LAN	1*100/M Support DHCP Server
	WiFi	AP+Station
	RS485	2* RS485
	RS232	1* RS232
Electrical Parameters	LED	Customizable
	Rated Voltage	DC12V, DC9~36V(Working Range)
	Rated Power	< 5W
	Power Protection	Anti-static, anti-surge, anti-reverse
Environmental Parameters	Certification	CE/ROHS/FCC
	Operating	-40~85°C
	Storage Temperature	-40~85°C
	Environment	10-90%RH (non-condensing)
Mechanical Parameters	Cooling Method	Heat sink/Dissipation silicone
	Size	118*90*35mm
	Weight	<1kg
Software Parameters	Material	Zinc Alloy
	Ops	Support remote configuration/upgrade/management
	VPN	Support intranet penetration/PLC remote upload&download/virtual serial port
	Edge Computing	Support visual programming, zero-code development, drag-and-drop
	Data Storage	Support cache queues/file read&write/disconnected transfer/ influxdb
	Industrial Agreement	Support multiple industrial protocols
	Network Protocol	MQTT/HTTP/TCP/UDP

## THE APPENDIX

## 附录



## EG8000 Series Edge Computing Gateway PLC Protocols

The gateway is categorized according to the hierarchical structure of **brand->protocol->model**, and representative PLC models are selected for testing in each category. The rest of the supported models are from the official documents.

Note: The gateway supports the standard MODBUS RTU/TCP protocol, which is supported by all mainstream PLCs. (For example, HollySys, Haiwell, Yokogawa, Runpower, etc.)

Brand	Protocol	Interface	PLC Model
SIEMENS (西门子)	<b>Tips:</b>		<b>Siemens in the sale of the series all support S7 protocol communication, it is recommended to use the S7 protocol communication.</b>
	S7	Ethernet	S7-S200smart、S7-S200 Series、S7-S300 Series、S7-S400 Series、S7-S1200 Series、S7-S1500 Series
	PPI	Serial port	S7-200 Series
MELSEC (三菱)	<b>Tips:</b>		<b>Mitsubishi mainly uses MC protocol for communication, FX5 Series, FX3 Series, Q Series, etc. are tested.</b>
	EtherNet/IP	Ethernet	FX5-ENET/IP Series、RJ71EIP91 Series、QJ71EIP71 Series
	MC-1E/MC-3E	Ethernet	FX5 Series、RJ71EN71 Series、RnENCPU Series、LJ71E71 Series、QJ71E71 Series、QnUCPU Series、FX3 Series
	MODBUS TCP	Ethernet	FX5 Series、RJ71EN71 Series、RnENCPU Series、LJ71E71 Series、QJ71E71 Series
	MC-3C	Serial port	FX5 Series、RJ71C24 Series、LJ71C24 Series、QJ71C24 Series
	MODBUS RTU	Serial port	FX5 Series、RJ71C24 Series、LJ71C24 Series、QJ71C24 Series、FX3 Series
	FxLinks	Serial port	FX3 Series、FX2 Series、FX1 Series、FX0 Series
	FxSerial	Serial port	FX3 Series、FX2 Series、FX1 Series、FX0 Series
OMRON (欧姆龙)	<b>Tips:</b>		<b>Omron mainly uses the Fins protocol for communication.</b>
	EtherNet/IP	Ethernet	NX7 Series、NX1 Series、NX1P Series、NJ Series、CJ1W-EIP21
	Fins	Ethernet	CP Series、CS Series、CJ Series、CV Series
	HostLink	Serial port	CP Series、CS Series、CJ Series、CV Series、C Series
LSis (LS 电气)	<b>Tips:</b>		<b>LS mainly uses FEnet/Cnet protocol for communication.</b>
	XGB FEnet	Ethernet	XGB Series (XBC/XEC U、XBL-EMTA)
	XGK FEnet	Ethernet	XGT Series (XGL-EFMT、XGL-EFMF、XGL-EH5T)
	XGB Cnet	Serial port	XGB Series (XBC/XEC U、XBL-C21A、XBL-C41A)
	XGK Cnet	Serial port	XGT Series (XGL-CH2A、XGL-C21A、XGL-C41A)

## THE APPENDIX

## 附录



Brand	Protocol	Interface	PLC Model
AllenBrandly (罗克韦尔)	<b>Tips:</b>		<b>Rockwell mainly uses CIP, DF1 protocol for communication.</b>
	EtherNet/IP	Ethernet	ControlLogix Series、CompactLogix Series、Micro800 Series (820、850、870)
	DF1	Serial port	ControlLogix Series、CompactLogix Series (5069-SERIAL module)、Micro800 Series (820、830、850、870) SLC Series (500、5/03、5/04、5/05)、Micro-Logix Series (1000、1100、1200、1500)
Beckhoff (倍福)	<b>Tips:</b>		<b>Beckhoff mainly uses the ADS protocol for communication.</b>
	ADS	Ethernet	CX Series、TwinCAT2、TwinCAT3
Inovance (汇川)	<b>Tips:</b>		<b>Inovance mainly adopts MODBUS protocol for communication.</b>
	MODBUS TCP	Ethernet	AC Series、AM Series、H5U Series、H3U Series
	MODBUS RTU	Serial port	AC Series、AM Series、H5U Series、H3U Series、H1U Series
Keyence (基恩士)	<b>Tips:</b>		<b>Keyence mainly uses the KV protocol for communication.</b>
	MC-3E	Ethernet	KV-8000 Series、KV-7000 Series、KV-5500 Series、KV-5000 Series、KV-EP21V、KV-LE21V、KV-LE20V、KV-LE20A and other Ethernet units
	KV	Serial port	KV-7300、KV-3000、KV-1000、KV-700、KV Nano、KV-L21V、KV-L20V
Panasonic (松下)	<b>Tips:</b>		<b>Panasonic mainly uses the Mewtocol protocol for communication.</b>
	MC-3E	Ethernet	FP7 Series、FP0H Series、FP-XH Series
	Mewtocol	Ethernet	FP7 Series、FP0H Series、FP-XH Series
Delta (台达)	<b>Tips:</b>		<b>Delta mainly uses MODBUS protocol for communication.</b>
	MODBUS TCP	Ethernet	AH Series、AS Series、AX-3 Series、DVP Series (built-in Ethernet)
	MODBUS RTU	Serial port	AH Series、AS Series、AX-3 Series、DVP Series
XinJE (信捷)	<b>Tips:</b>		<b>XinJE mainly uses MODBUS protocol for communication.</b>
	MODBUS TCP	Ethernet	CCSD Series、XA Series、XS Series、XG Series、XL Series
	MODBUS RTU	Serial port	CCSD Series、XA Series、XS Series、XG Series、XL Series、XC Series、XD Series
MegMeet (麦格米特)	<b>Tips:</b>		<b>MegMeet mainly uses MODBUS protocol for communication.</b>
	MODBUS TCP	Ethernet	MC5100 Series、MC280 Series、MC200 Series、MC100 Series、MC80 Series
	MODBUS RTU	Serial port	MC5100 Series、MC280 Series、MC200 Series、MC100 Series、MC80 Series
Yaskawa (安川)	<b>Tips:</b>		<b>Yaskawa mainly uses the MEMOBUS protocol for communication (supports S7).</b>
	Memobus	Ethernet	GL120/130 Series、GL60 Series、MP3000 Series、MP2300 Series、Z1000 Series
Fatek (永宏)	<b>Tips:</b>		<b>Fatek mainly uses the Fatek protocol for communication.</b>
	Fatek	Serial port	FBs Series
Vigor (丰炜)	<b>Tips:</b>		<b>Vigor mainly uses the VS private protocol for communication.</b>
	VS	Serial port	VS Series
Fuji (富士)	<b>Tips:</b>		<b>Fuji mainly uses the SPH/SPB protocol for communications.</b>
	SPH	Ethernet	SPH Series
	SPB	Serial port	SPB Series

WIRING INSTRUCTION  
接线说明 ▶▶▶

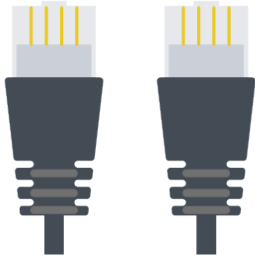
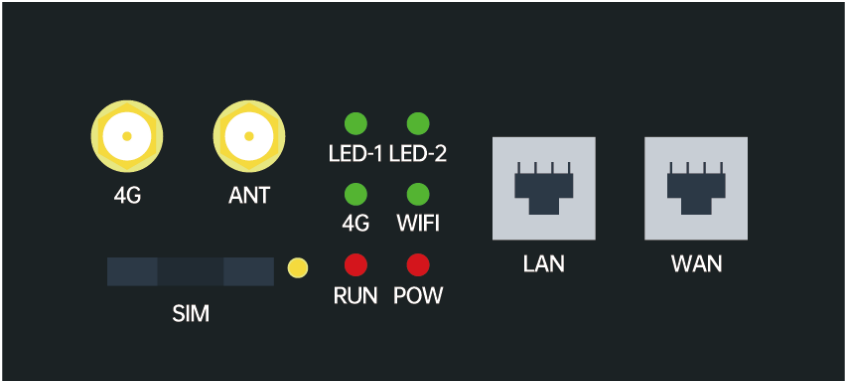

Interface Identification-1

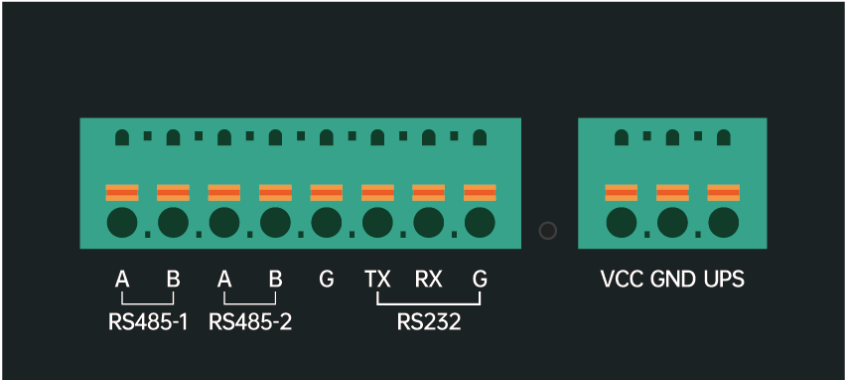

Interface Identification-2



WIRING  
INSTRUCTION

接线说明

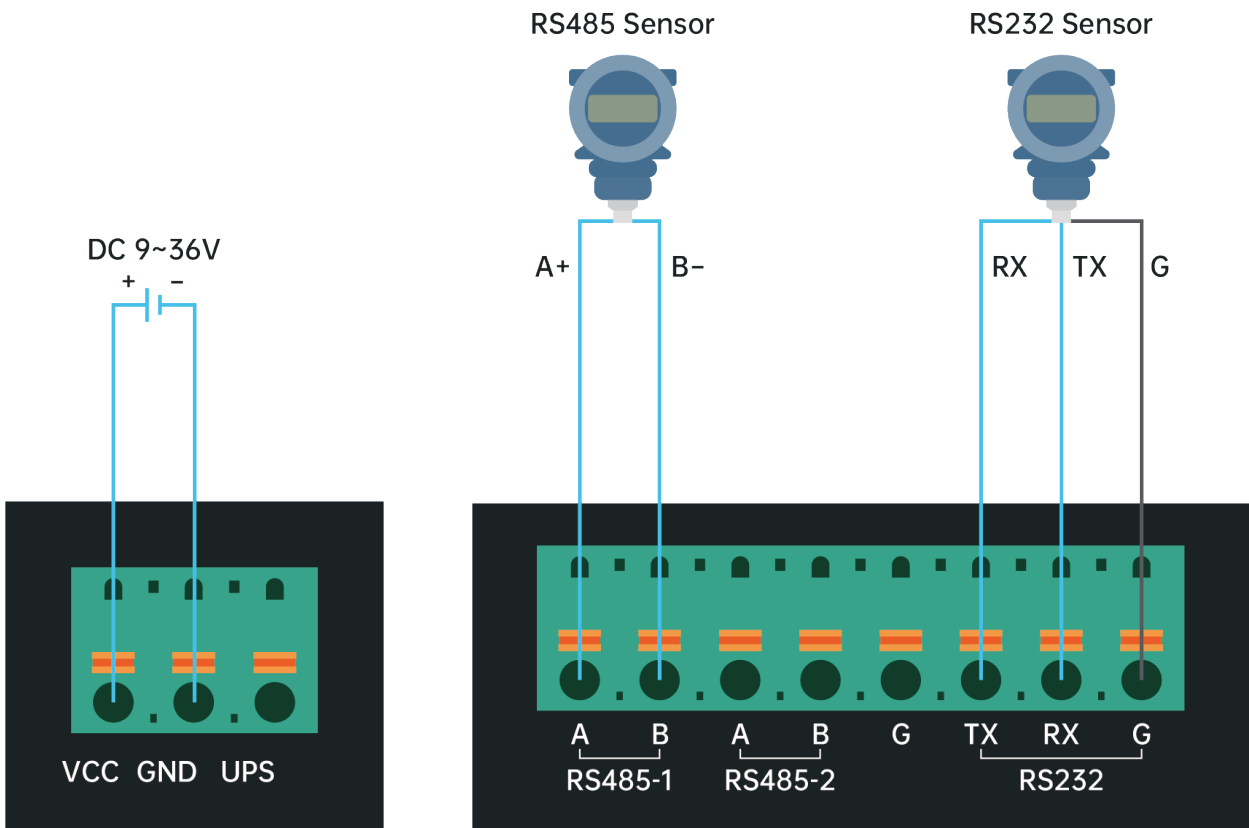

Power Wiring Diagram

RS485/RS232 Wiring Diagram

# LEADING IOT DATA COMMUNICATION EQUIPMENT PROVIDER

R&D Center :  
CHENGDU IOTRouter TECHNOLOGY CO., LTD  
No. 599, Section 1, Huafu Avenue, Shuangliu  
District, Chengdu city, Sichuan Province, China

Website :  
[www.iot-router.com](http://www.iot-router.com)

Mail :  
[agnes@iotrouter.com](mailto:agnes@iotrouter.com)



WhatsApp